

DATA SUMMARY

LOCATION

Date and time	Thursday, 21 June 2007; 18:40 local time¹
Site	Abanilla (Murcia)

AIRCRAFT

Registration	EC-HYM
Type and model	BELL 412
Operator	Helicópteros del Sureste, S. A.

Engines

Type and model	PRATT & WHITNEY PT6T-3B
Number	2

CREW

Pilot in command

Age	50 years old
Licence	Commercial helicopter license CPL(H)
Total flight hours	5,040 h
Flight hours on the type	2,951 h

INJURIES

	Fatal	Serious	Minor/None
Crew			1
Passengers			
Third persons			

DAMAGE

Aircraft	Significant
Third parties	None

FLIGHT DATA

Operation	Aerial work – Commercial – Fire fighting
Phase of flight	Landing

REPORT

Date of approval	
------------------	--

¹ The reference time used in this report is local time. To obtain UTC, subtract two hours from local time.

1. FACTUAL INFORMATION

1.1. Description of event

The helicopter was taking part in efforts to extinguish a forest fire in the El Canton mountain range, located north of Mascivenda, within the municipal limit of Abanilla (Murcia). On board was the pilot, who was using a bambi bucket to perform the water drops. After releasing several loads, he left the bambi bucket on the ground near the fire. The terrain was irregularly shaped and slightly inclined. The maintenance technician then boarded the helicopter and they proceeded to the base in Alcantarilla (Murcia) to refuel.

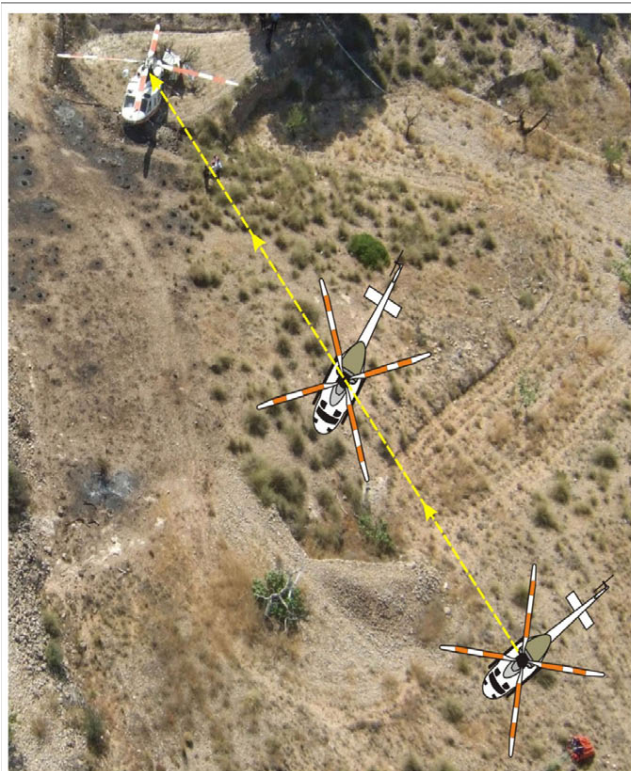

Figure 1. Relative positions of helicopter and bambi bucket

After refueling, they went back to pick up the bambi bucket and they landed. The mechanic exited and went to the front of the helicopter so as to hook up the bambi bucket. At that moment, while the aircraft was resting on the ground but with a certain amount of lift (the collective was not completely down and locked), it started to vibrate vertically. The pilot stated that he decided to climb to try to eliminate the vibrations, but when they did not subside, he tried to land once again, moving laterally a distance of some 50 m (see Figure 1) across a terrain that was at about an 8° incline. During this maneuver the blades of both rotors struck a tree and the helicopter fell to the ground at coordinates 38° 16' 37" N, 1° 0' 20" W, with the nose facing to the northwest. As a consequence of the impact a fire broke out that affected part of the passenger cabin, though it was immediately extinguished using equipment available in the area.

The pilot was not injured and exited the aircraft under his own power.

There was significant damage to the main rotor, two blades of which (blue

and yellow) were severely affected, the tail cone (the aft half of which detached), and the landing gear skids.

According to information provided by the AEMET, winds in the area were from the south at 14 kt, gusting up to 25 kt.

1.2. Aircraft information

The Bell 412 helicopter, serial number 33045, was manufactured in 1981 and was outfitted with two Pratt & Whitney PT6T-3B engines. It had a valid normal airworthiness certificate.

This aircraft had logged a total of 950 flight hours in Central America from 1982 to 1985. It was then mothballed for 16 years before being taken to Canada in 2001 for return to service maintenance, shortly after which it started operations in Spain, accumulating a total of 2,100 flight hours over the next six years, up to the time of the accident (Helicopter total time was approximately 2,100 h at time of accident and the helicopter had accumulated approximately 1,150 h while operating in Spain). This type of helicopter has an Automatic Flight Control System (AFCS) that can operate in SAS mode to maintain flight stability, or in ATT mode to maintain attitude.

The flight manual specifies that the maximum allowed wind speed is 35 kt (see Figure 2) for a density altitude equal to or below 3,000 ft when the wind is from the left aft quadrant or from a relative angle between 45° and 105°. It also states that while hovering when the helicopter is subject to ground effect, the longitudinal motion of the cyclic lever is critical when the wind is from said range of angles, and can interfere with the proper operation of the AFCS if ATT mode is engaged. During the investigation it was not possible to determine the system's mode of operation.

At the time of the accident the flight manual also specified a lateral slope limit of 10° for landing the helicopter. On 31 October 2007, a revision to the manual was issued which maintained the lateral slope limit and added a maximum longitudinal slope limit of 4°. It

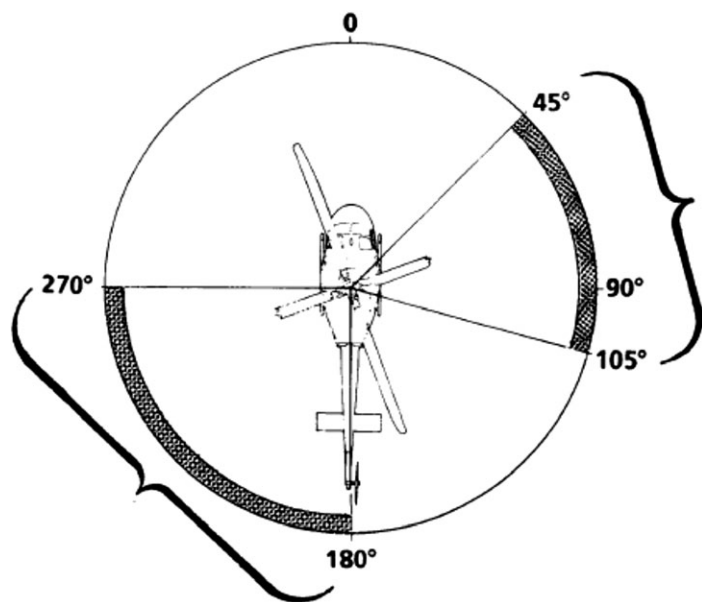

Figure 2. Wind limitations

also included a note warning that wind conditions, the location of the center of gravity and the ground characteristics could reduce these values below the published maximums.

In this helicopter, the transmission is connected to the structure through two different devices. One of them, the lift link, is used to connect the gearbox directly to the structure, and is designed to absorb all loads between the rotor and the structure. It is made of forged steel and it includes a bearing at one end. The other component consists of four pylon isolation mounts that are located below the four corners of the main gearbox and joined to it. They are also affixed to the structure by means of four bolts each. These bolts are of different lengths (two long and two short). The bolts are arranged in a pattern specified by the maintenance manual and the pattern is different between the front mounts and the aft mounts. The mounts are designed to isolate rotor vibrations and keep them from being passed to the structure by means of an elastomer compound inside the mounts. Between the structure and the mount there is a spacer that serves to keep the mount in a fixed position. Each set of mounts consists of the piece that houses the elastomer material within it, the spacer and the bolts.

The maintenance manual recommends replacing the mounts when vibrations appear, as this could indicate a defect, or when there is evidence of a malfunction. It also provides a procedure for checking the condition of the mounts and determining whether to replace them.

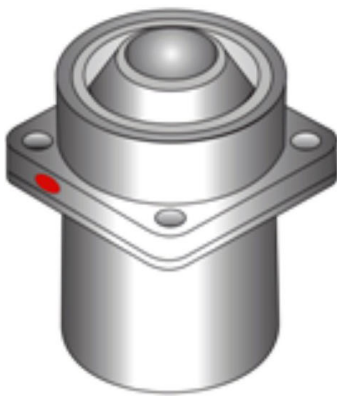

Figure 3. Part of a mount

The operator reported that it was unaware of the presence of vibrations prior to the accident or of any signs of a malfunction. No anomalies were noted during the visual inspections, so it was considered unnecessary to apply said procedure.

On 20 July 1992, the manufacturer issued Technical Bulletin 412-92-111, which affected a certain number of helicopters with serial numbers that included 33045, and which recommended that any mounts with part number 204-031-927-105 be replaced by those with part number 204-031-927-107, as these offered improved performance in absorbing the vibrations transmitted by the main rotor. According to the bulletin, there was no flight hour prerequisite to carry out the replacement, though it did mention that both types of mounts could not be used at the same time. (On 5 January 2009, Bell issued Alert Service Bulletin 412-09-132, removing all -105 pylon mounts from service, replacing them with -107 mounts).

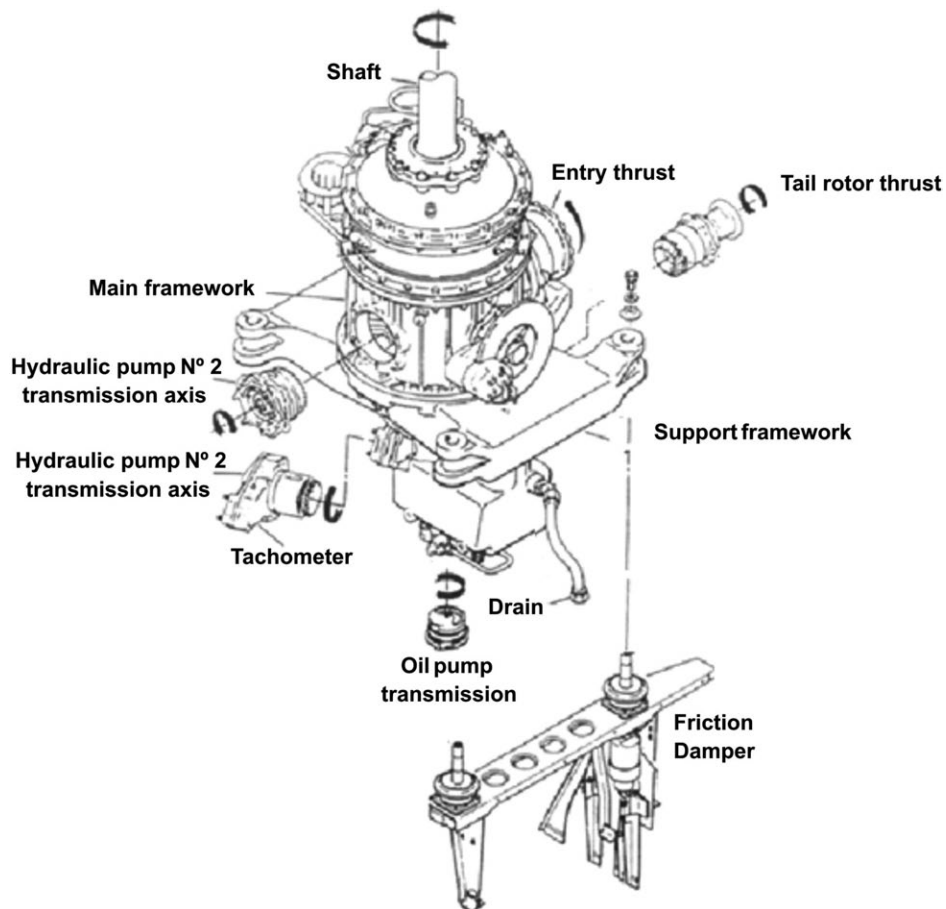

Figure 4. Support mount for structure and gearbox

1.3.- Check of the wreckage

The post-accident investigation revealed that the friction of the collective control, which can only be adjusted during maintenance, was near the minimum required limit, and also that the aircraft flight controls properly transmitted their motion to the main rotor, which was within specified limits in terms of play and the condition of the pitch control links. No damage was noted to the main rotor hub or to the blade connections.

The landing gear rear cross tube was in good condition, pivoting freely to both sides. The screw on which the arch pivots did not show any signs of damage. No wear or excessive play was noted.

The four mounts were disassembled, which revealed that the bolts in the front left mount had been swapped. The front left bolt was short instead of long, and the two rear bolts were long instead of short. The right aft mount also had the wrong right front bolt (long instead of short). Despite this, there were no signs of fretting between the

mating surfaces of the mounts and spacers or between the spacers and pylon support channel in any of the four assemblies.

Over the course of the inspection it was noted that during the time the helicopter had been in service in Spain, the mounts had not been replaced, though it is not known whether these are the same mounts that were originally installed when the helicopter was manufactured.

The four mount assemblies with P/N 204-031-927-105 (including the four bolts attached to each and the attachment fittings) were sent to the manufacturer for analysis. It was found that some of the fastening bolts on the front mounts were bent, although all conformed with design hardness requirements.

There was corrosion on the inner wall of the outer surface of the front left mount housing, which had caused part of the outer cover of the elastomer material to detach.

The depth of the cracks on the elastomer material of the mounts was checked. Only the front left mount was within specified limits (the maintenance manual states that the mounts must be replaced if the depth of the cracks exceeds 0.25 inches).

When the distance (height) between the upper ends of the internal and external parts of the mounts was measured, it was noted that none of the four mounts complied with design requirements.

The elasticity indices, both static and dynamic, of the mounts were also checked. It was noted that the static elasticity index on two mounts was below the range required in at least one direction, and three had dynamic elasticity indices outside design requirements. The manufacturer reported that although the mounts function while hovering, the fact that the elasticity indices on some of them were below the required range along at least one axis could result in a change in the way the assembly dampens vibrations from the transmission, such that it could resonate with the main rotor vibrations causing excessive lateral movement and hampering control of the helicopter.

2. ANALYSIS

When the vibrations occurred, the wind was blowing from the helicopter's left aft quadrant with an intensity, including the gusts, far below the maximum allowed. It seems, therefore, that the wind did not have a determining influence on the longitudinal cyclic control that could have resulted in any type of vibration.

The post-accident inspection revealed that some of the bolts used to attach the mounts were not adequately installed. It is important that these bolts be properly

installed since if a short bolt is inserted in a hole intended for a long bolt, it will not be fully threaded and the mount will be improperly attached, which could result in its failure. When a long bolt is inserted in a short hole, the neck of the bolt could reach the female thread before the necessary grip is obtained. If the bolt continues to be turned, the neck area will interfere with the female thread, resulting in damage to both. This could result in the bolt tightening torque being reached solely due to the friction from the threads on the neck and not the result of a proper tensile clamping force. Therefore, the mount would not be properly attached but would be loose due to an insufficient clamping force, which may allow fretting wear to occur between mating surfaces. In this case no wear was found on any of the four assemblies. Thus, despite the importance of installing the bolts in the right position, it does not appear that the deterioration at the time of the accident was such that having a few bolts in the wrong place would have had a direct influence on the appearance of the vibrations.

There were three factors, however, that probably caused the appearance of the vibrations.

The first factor was that the collective stick was not at a full down position when the helicopter was on the ground.

Another factor was the deterioration evident in the four mount assemblies, since one was corroded along its inner diameter, which had led to significant deterioration of the elastomer to the point that it was no longer within design specifications for static or dynamic spring rates. It is very likely that the corrosion resulted from water penetrating inside the mounts during all the time that the helicopter was out of service due to an improper state of preservation, and that this fact also contributed to the index of elasticity of some of the mounts being below minimum requirements in at least one direction.

The third factor was the fact that when the pilot landed to drop off the bambi bucket, he did so on an incline with an irregular surface and in adverse wind conditions. Although at the time of the accident there was no longitudinal slope restriction specified in the flight manual, the fact that a short time later the manufacturer modified the manual to impose a 4° restriction is indicative of how sensitive the helicopter is to this factor.

3. CONCLUSION

The cause of the accident is considered to be the appearance of vibrations that hampered control of the helicopter and degraded flight conditions, which forced the pilot to make an immediate landing, resulting in the helicopter impacting a tree.

The appearance of vertical vibrations could result from the simultaneous occurrence of three factors:

- The helicopter collective stick was not in the full down flat pitch position which may have allowed vibratory interactions between the main rotor and airframe.
- The loss of the mounts' ability to absorb the vibrations transmitted by the turning rotor to the structure and resulting from the degraded mechanical characteristics of the assemblies, as evidenced by the cracks and corrosion present inside one of the components. Degradation in the static and dynamic spring rates of the mounts (softening) would lower the pylon roll mode frequency and into resonance or near resonance with the main rotor 1/rev vibration.
- The previous landing on terrain with an irregular surface and inclined at an angle above that specified in the helicopter manual and in adverse wind conditions.