

CIAIAC

COMISIÓN DE
INVESTIGACIÓN
DE **A**CCIDENTES
E **I**NCIDENTES DE
AVIACIÓN **C**IVIL

Report A-018/2020

Accident on 20 June 2020,
involving a TECNAM P2002-JF
aircraft operated by FlyBai,
registration EC-MOH, at Burgos
Airport



GOBIERNO
DE ESPAÑA

MINISTERIO
DE TRANSPORTES, MOVILIDAD
Y AGENDA URBANA

Edita: Centro de Publicaciones
Secretaría General Técnica
Ministerio de Transportes, Movilidad y Agenda Urbana ©

NIPO: 796-22-019-9

Diseño, maquetación e impresión: Centro de Publicaciones

COMISIÓN DE INVESTIGACIÓN DE ACCIDENTES E INCIDENTES DE AVIACIÓN CIVIL

Tel.: +34 91 597 89 63
Fax: +34 91 463 55 35

E-mail: ciaiac@mitma.es
<http://www.ciaiac.es>

C/ Fruela, 6
28011 Madrid (España)

FOREWORD

This report is a technical document that reflects the point of view of the Civil Aviation Accident and Incident Investigation Commission (CIAIAC) regarding the circumstances of the accident and its causes and consequences.

In accordance with the provisions in Article 5.4.1 of Annex 13 of the International Civil Aviation Convention; and with articles 5.6 of Regulation (UE) n° 996/2010, of the European Parliament and the Council, of 20 October 2010; Article 15 of Law 21/2003 on Air Safety and articles 1 and 21.2 of Regulation 389/1998, this investigation is exclusively of a technical nature, and its objective is the prevention of future civil aviation accidents and incidents by issuing, if necessary, safety recommendations to prevent from their reoccurrence. The investigation is not pointed to establish blame or liability whatsoever, and it's not prejudging the possible decision taken by the judicial authorities. Therefore, and according to above norms and regulations, the investigation was carried out using procedures not necessarily subject to the guarantees and rights usually used for the evidences in a judicial process.

Consequently, any use of this report for purposes other than that of preventing future accidents may lead to erroneous conclusions or interpretations.

This report was originally issued in Spanish. This English translation is provided for information purposes only.

Contents

- Abbreviations** 4
- Synopsis** 6
- 1. FACTUAL INFORMATION** 7
 - 1.1. History of the flight..... 7
 - 1.2. Injuries to persons..... 7
 - 1.3. Damage to the aircraft..... 7
 - 1.4. Other damage..... 7
 - 1.5. Personnel information 8
 - 1.6. Aircraft information..... 8
 - 1.7. Meteorological information 10
 - 1.8. Aids to navigation..... 10
 - 1.9. Communications 10
 - 1.10. Aerodrome information..... 11
 - 1.11. Flight recorders 13
 - 1.12. Aircraft wreckage and impact information..... 13
 - 1.13. Medical and pathological information..... 14
 - 1.14. Fire..... 14
 - 1.15. Survival aspects 14
 - 1.16. Tests and research 14
 - 1.17. Organisational and management information 15
 - 1.18. Additional information 17
 - 1.19. Useful or effective investigation techniques 22
- 2. ANALYSIS** 23
 - 2.1. Analysis of the breakage of the main landing gear mounting elements..... 23
 - 2.2. Maintenance analysis 24
 - 2.3. Operational analysis 25
 - 2.4. Analysis of the actions taken by the AFIS unit..... 25
- 3. CONCLUSIONS** 27
 - 3.1. Findings..... 27
 - 3.2. Causes/contributing factors..... 27
- 4. OPERATIONAL SAFETY RECOMMENDATIONS** 28

Abbreviations

° ' "	Sexagesimal degree(s), minute(s) and second(s)
°C	Degree(s) Celsius
%	Per cent
AESA	Spain's National Aviation Safety Agency
AFIS	Aerodrome flight information service
AFM	Aircraft flight manual
AIP	Aeronautical Information Publication
AMM	Aircraft maintenance manual
AR	Aerobatic rating
ARO	Air traffic service reporting office
ATO	Approved training organisation
ATPL(A)	Airline Transport Pilot License
CAVOK	Clouds, visibility and weather conditions better than prescribed values or conditions
CB	<i>Cumulonimbus</i>
CPL(A)	Commercial Aircraft Pilot License
CR(A)	Class rating
CRI	Class rating instructor
FI(A)	Flight Instructor rating
FIZ	Flight information zone
ft	Feet(s)
h	Hour(s)
hPa	Hectopascal(s)
IR(A)	Instrument rating
IRI(A)	Instrument instructor rating
kg	Kilogrammes
KIAS	Knots-indicated airspeed
kt	Knot(s)
LEBG	ICAO code for Burgos Airport
LEVTAPP	Approach control at Vitoria Airport
m	Metre(s)
m ²	Metre(s) squared
MEP	Multi-engine piston aircraft rating
METAR	Aviation routine weather report (in aeronautical meteorological code)
MHz	Megahertz(s)
mm	Millimetre(s)
Nm	Newton-metres
NOTAM	A notice distributed by means of telecommunication containing information concerning the establishment, condition or change in any aeronautical facility, service, procedure or hazard, the timely knowledge of which is essential to personnel concerned with flight operations
P/N	Part number
PPL(A)	Private Aircraft Pilot License

Report A-018/2020

QNH	Altimeter subscale adjustment to obtain elevation while over land (precision adjustment to indicate elevation above mean sea level)
S.L.	Limited company
S/N	Serial number
SB	Service Bulletins
SEI	Fire extinguishing service
SEP	Single-engine piston aircraft rating
SOP	Standardised operational procedures
T/O	Take off
TCU	Towering cumulus
UTC	Universal Time Coordinated
VFR	Visual flight rules
W	West

Synopsis

Owner and operator:	FlyBai
Aircraft:	Tecnam P2002-JF, registration EC-MOH
Date and time of incident:	Saturday, 20 June 2020: 17:18 h ¹
Site of accident:	Burgos Airport (LEBG)
Persons on board:	Two crew, uninjured
Type of flight:	General aviation – Flight training – Dual
Phase of flight:	Landing - Landing roll
Flight rules:	VFR
Date of approval:	30 June 2021

Summary of incident

The aircraft landed on runway 22 at Burgos Airport after a local dual training flight.

During the landing roll, when the aircraft had already slowed down, the left main landing gear leg detached.

The aircraft came to a halt on the runway, resting on its right and front landing gear legs and left-hand wing and horizontal stabiliser tips.

The two occupants of the aircraft were uninjured.

The investigation has determined the cause of the accident was the detachment of the left main gear due to the failure of the mounting assemblies.

The application of excessive tightening torque on the left main landing gear's outer mounting nuts is thought to be a contributing factor.

The report contains one safety recommendation addressed to Fly Bai Mantenimiento, S.L., as the organisation responsible for maintaining the aircraft.

¹ Unless otherwise indicated, all times in this report are expressed in local time. UTC can be calculated by subtracting two units from the local time.

1. FACTUAL INFORMATION

1.1. History of the flight

On 20 June 2020, the Tecnam P2002-JF aircraft with registration EC-MOH took off at 15:50 h from Burgos Airport to carry out a local training flight lasting an hour and a half to practice basic manoeuvres. An instructor and student were on board the aircraft.

According to the instructor's statement, the flight proceeded normally. They returned to the airport to land on runway 22. As the student was still inexperienced, the instructor landed the aircraft. As the aircraft was decelerating during the landing roll, the left landing gear leg began to give way



Figure 1. Photograph of the aircraft

and eventually collapsed. As a result, the wing dropped down and made contact with the runway. The instructor secured the engine, communicated the fact that the aircraft was immobilised on the runway by radio and ordered the evacuation.

The instructor and student were uninjured and evacuated the aircraft without assistance.

1.2. Injuries to persons

Injuries	Crew	Passengers	Total in the aircraft	Others
Fatal				
Serious				
Minor				N/A
None	2		2	N/A
TOTAL	2		2	

1.3. Damage to the aircraft

The aircraft suffered damage to its main landing gear left leg, left flap, left horizontal stabiliser and left wingtip.

1.4. Other damage

No other damage sustained.

1.5. Personnel information

1.5.1. Flight Instructor

The 28-year-old instructor had a commercial pilot license (CPL) issued by Spain's National Aviation Safety Agency (AESA) on 24 January 2014, with a B737 300-900 rating valid until 30 April 2021, single-engine rating (SEP) valid until 31 December 2020, and an instrument flight rating (IR (A)) valid until 30 April 2021. He also had an aerobatic flight rating (AR) and flight instructor rating (FI), both valid until 31 July 2020, which authorised him to act as an instructor for private and commercial pilot training and single-engine and aerobatic flight ratings.

The instructor had a Class 1 medical certificate valid until 20 January 2021.

The instructor's overall flight experience was 4747:31 h, of which he had 2,507 h in a B737-800 aircraft, 2240 h as pilot-in-command and 1642 as an instructor.

1.5.2. Information about the student

The 29-year-old student pilot had a Class 1 medical certificate valid until 02 June 2021. The student was enrolled on the integrated airline transport pilot programme. At the time of the accident, the student had accumulated seventeen flight hours, all of which were under dual-command.

1.6. Aircraft information

1.6.1. General information

The aircraft involved in the accident, a Tecnam P2002-JF, is a low-wing aircraft equipped with a tricycle-type fixed landing gear, built in 2016, with serial number 302.

Its general characteristics are as follows:

- Wingspan: 8.60 m
- Length: 6.61 m
- Height: 2.43 m
- Wing area: 11.50 m²
- Empty weight: 400.0 kg
- Maximum take-off weight: 620 kg
- Track width: 1.85 m
- Wheelbase: 1.62 m
- Engine, Rotax 912S2-01, s/n: 9139188
- Propeller: fibre two-blade fixed pitch

1.6.2. Description of the landing gear mounting system

This aircraft has a fixed tricycle-type landing gear.

The main gear consists of two leaf spring dampers fixed to the airframe at cabin seat height.

Figure 2 shows a diagram of one of the legs.

As shown in the diagram, the legs are fixed to the structure with one nut and bolt assembly in the inner area, and with a flange, two nut and bolt assemblies and a leather spacer in the exterior area.

1.6.3. Airworthiness and maintenance of the aircraft

The aircraft had an Airworthiness Certificate, issued by Spain's National Aviation Safety Agency on 2 February 2017, and an Airworthiness Review Certificate issued in 01/02/2020 by the CAMO that manages the aircraft (AVIATION VIP, ES.MG.181), which it was valid until 1 February 2021.

At the time of the accident, the aircraft had accrued 2246:10 hours, and the engine had 246:10 hours.

The organisation responsible for maintaining the aircraft was FlyBai Mantenimiento, S.L., an AESA-approved maintenance organisation with reference ES.MF.024 according to Subpart F (Part M) of EU Regulation No.1321/2014.

The last maintenance inspection of the aircraft was carried out on 19 June 2020 (the day before the event) and comprised a 50-hour inspection, with the aircraft having 2240:30 flight hours.

According to the aircraft maintenance manual (P2002JF *Maintenance Manual* Sec.5-20 Edición 2 nº de Rev. 4), in a type A revision (50 h), only one task is performed on the landing gear system (ATA32) to check the correct tightening torque of the main landing gear attachment bolts and replace the leather spacer, if necessary. The *Maintenance Manual* indicates that the tightening torque for the nuts of the outer bolts (AN-365-524A) should be 15 ± 1 Nm, while it should be $25 +3/-2$ Nm for the inner bolts (AN-365-624A).

According to the certificate to release to service for the inspection, this task was carried out.

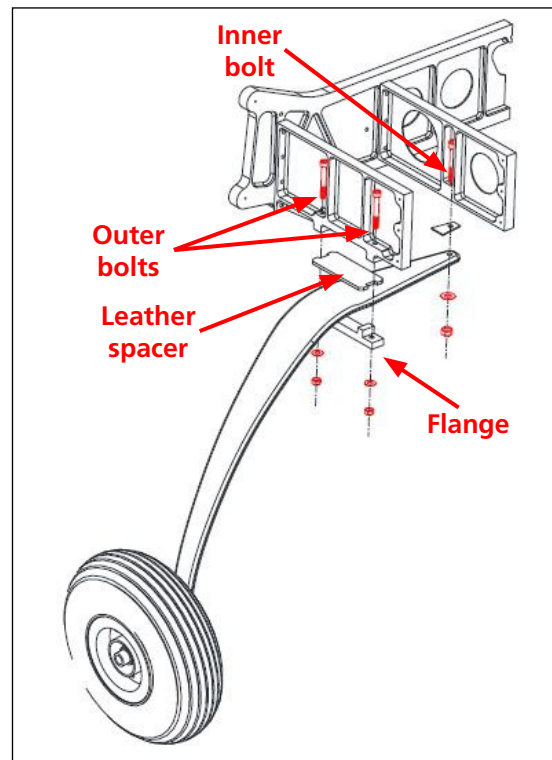

Figure 2. Main landing gear diagram

On 13/03/2020, a type B maintenance inspection was carried out (50 + 100 h). This inspection specifies 13 tasks to be performed on the landing gear system, one of which is to check the torque of the mounting bolts. The certificates to release to service confirm that all the specified tasks were carried out.

We were also able to confirm that technicians carried out all the required maintenance tasks in the two previous maintenance inspections, on 24/02/2020 (type B) and 06/02/2020 (type A).

According to the information provided by the maintenance organisation, the tightening torque of the landing gear bolts was checked using a Britool torque wrench, the last calibration of which was valid until 23/10/2020. The technicians torqued the inner bolt to 25 Nm and the exterior bolts to 15 Nm.

1.7. Meteorological information

The METAR for Burgos on 20 June at 17:00 local time was as follows:

METAR LEBG 201500Z 29004KT 220V360 CAVOK 25/06 Q1023=

The Burgos METAR at 15:00 UTC indicated that the wind direction was 290° with a speed of 4 kt. The wind direction was variable, from 220° to 360°. Visibility in excess of 10 km. Absence of clouds below the CAVOK reference height and no *cumulonimbus* (CB) or towering *cumulus* (TCU). No significant weather phenomena. Temperature 25°C, dew point 6°C, QNH 1,023 hPa.

1.8. Aids to navigation

Not applicable.

1.9. Communications

We reviewed the communications that took place around the time of the accident, the most significant being the following:

At 15:00 UTC, the AFIS operator issued the following message notifying the end of the service: "to all stations, Burgos Aerodrome Flight Information Service Terminated. *A todas estaciones Burgos Información Servicio AFIS de Burgos Terminado*".

At 15:18 UTC, the aircraft with callsign FBY1E1 (EC-MOH) notified all traffic that one of its landing gear legs had detached and they were still on the runway, requesting that no other aircraft attempt to land.

Immediately afterwards, the AFIS operator called the fire extinguishing service (SEI) to report the incident.

At 15:19, the AFIS called aircraft FBY1D3S, which was on final, explaining that although the AFIS service had ended, it was informing them that the runway was occupied by an aircraft that was currently unable to move.

At 15:20, the AFIS operator spoke with LEVTAPP² and ARO³ reporting the incident.

From that moment until 16:02 UTC, when the runway was re-opened, the AFIS operator coordinated between the SEI, ARO, LEVTAPP and aircrafts in flight.

Between 16:02 and 17:00, the AFIS was fully operational, providing aerodrome information to the aircraft within its service zone (FIZ).

1.10. Aerodrome information

Burgos Airport has a 2100 m long and 45 m wide paved runway, designated 04-22. The runway is equipped with threshold markings, runway designators, side strip, centre line and an aim point.

The runway is connected to the aircraft parking apron (APN1) by two taxiways perpendicular to the runway, designated A and B.

A third taxiway, "C", connects the runway with another parking apron, called the hangar service apron.

² Approach control at Vitoria Airport

³ Air traffic service reporting office

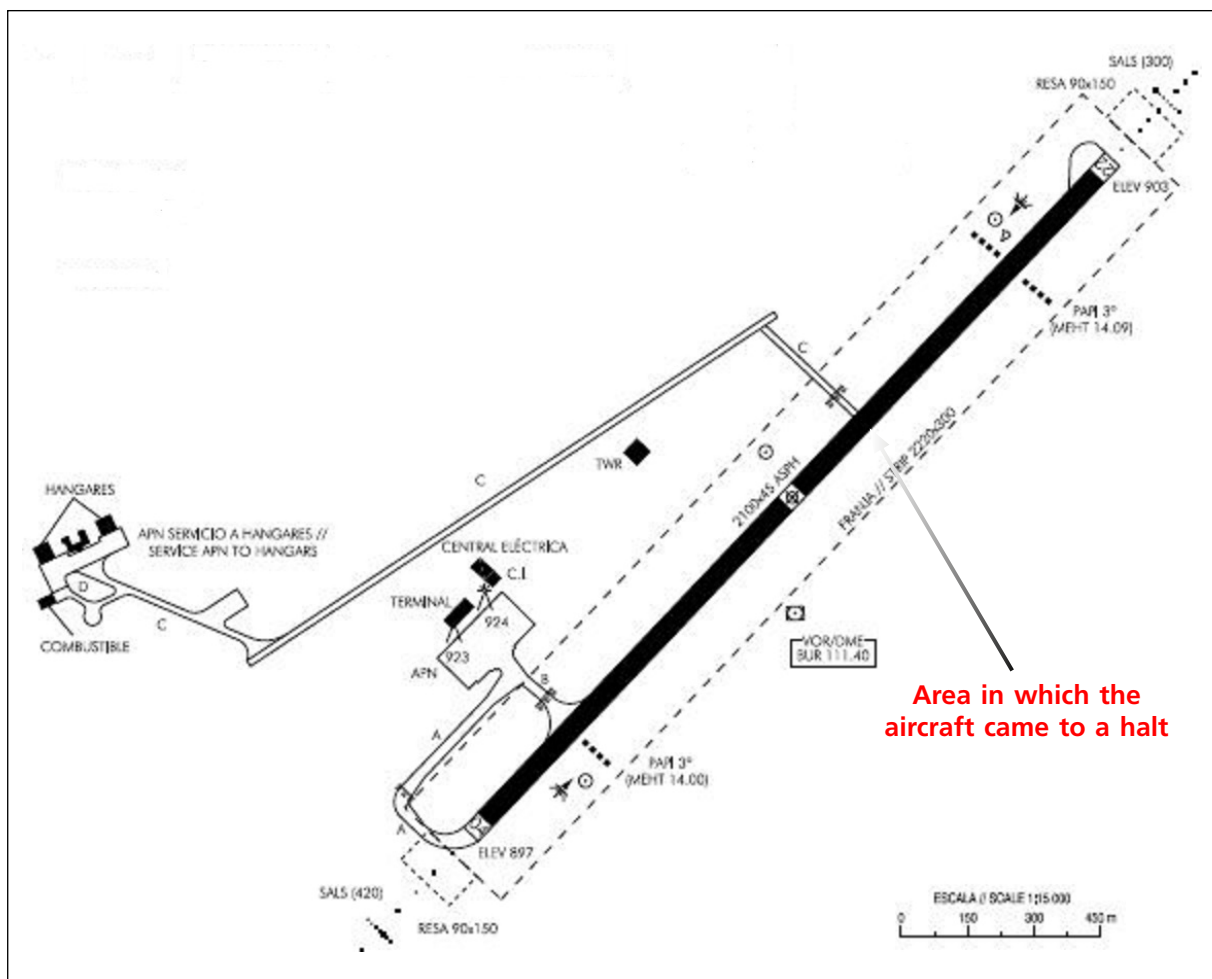

Figure 3. Airport plan extracted from the ICAO aerodrome plan (AD 2-LEBG ADC) published in the Spanish AIP

The facility operates in two different ways: as an airport for public use and as a restricted aerodrome. According to information from the Spanish AIP, on the date of the incident (summer season) the hours of operation were as follows:

- Public use: Monday to Friday, from 08:30 to 16:00 UTC (10:30 to 18:00 local time)
- Restricted use: Monday to Friday, from 06:00 to 08:30 and 16:00 to 18:00 UTC
Saturdays, from 07:30 to 16:30 UTC
Sundays, from 07:30 to 17:00 UTC

An aerodrome information service (AFIS) is provided during the public use hours. The communications frequency of this service is 125.425 MHz.

The same frequency is used for communications between pilots during the restricted use hours, in which the AFIS is not provided.

On the Saturday the accident occurred, the hours of operation differed from those published in the AIP because the AFIS service was provided between 04:00 and 15:00 UTC, as announced through the following NOTAM:

B3842/20 NOTAMN Q) LECM/QSFAH/IV/B /A /000/999/4221N00337W005 A)LEBG B)2006201600 C)2006201700 E)AFIS HOURS OF OPERATION JUN 20 1600-1700 SEE NOTAM 3230/20.

The accident took place at 17:20 h (15:20 UTC), when the AFIS service had already ended. The AFIS operator, who was still in the unit, heard the aircraft crew notify all traffic on the communications frequency that their landing gear had broken leaving them stuck on the runway and, therefore, that no other aircraft should land.

The AFIS operator called the fire brigade to inform them of the accident. Furthermore, and even though the AFIS service had officially ended, the operator decided to inform the FBY1D3S traffic on final that the runway was occupied.

He then reported the event to LEVTAPP and the ARO.

In total, there were three aircraft scheduled to land in Burgos. At around 15:44 UTC, one of them reported it was running low on fuel.

The AFIS operator requested the ARO publish a NOTAM to re-open the information service between 16:00 and 17:00 UTC, in order to manage the three aircraft in the air.

Eventually, the three aircraft landed safely.

1.11. Flight recorders

The aircraft was not equipped with a flight data recorder or a cockpit voice recorder, as the aeronautical regulations in force do not require the fitting of these recorders on these types of aircraft.

1.12. Aircraft wreckage and impact information

The aircraft stopped and remained stranded on the runway, level with taxiway C close to its left side (depending on the landing direction), at a distance of about 800 m from the head of runway 22.



Figure 4. Photographs of the aircraft on the runway and the nut and bolt fragments found on the runway. The left main landing gear had detached, and was on the runway a few metres behind the aircraft (see figure 4).

A light, roughly 5 m-long mark made by the tip of the left wing was the only visible mark on the runway.

A leather spacer, a fragment of a bolt and two nuts were also found on the runway.

The two nuts had lost their threads. Pieces of nut threads could be seen between the threads of the bolt fragment.

1.13. Medical and pathological information

Not applicable.

1.14. Fire

There was no fire.

1.15. Survival aspects

The aircraft maintained its shape and did not suffer any appreciable deformations. The safety belts adequately restrained the occupants and the seats maintained their shape and location.

1.16. Tests and research

1.16.1. Aircraft inspection

The aircraft was transferred to a hangar at Burgos Airport, where it was inspected.

The left main landing gear had separated from the aircraft. The mounting flange was only attached to the airframe by the rear bolt. This bolt was bent sharply backwards. The mounting flange also displayed some slight deformation.

The front bolt remained inside its housing in the airframe but had lost its nut.

The inner mounting bolt was also in its housing inside the structure, although it had snapped at the first thread. The bolt fragment found on the runway matched the missing part of the inner bolt.

The two nuts found on the runway were for the inner bolt and the outer front bolt.

We examined the right landing gear leg fixings to check that they were in a normal condition.

The tightening torque applied to the nuts was verified using a nut wrench adjusted to 25 Nm (inner bolt) and 15 Nm (outer mounting bolts). The wrench clicked before the nuts were turned, indicating that the bolts were tightened to at least that torque.

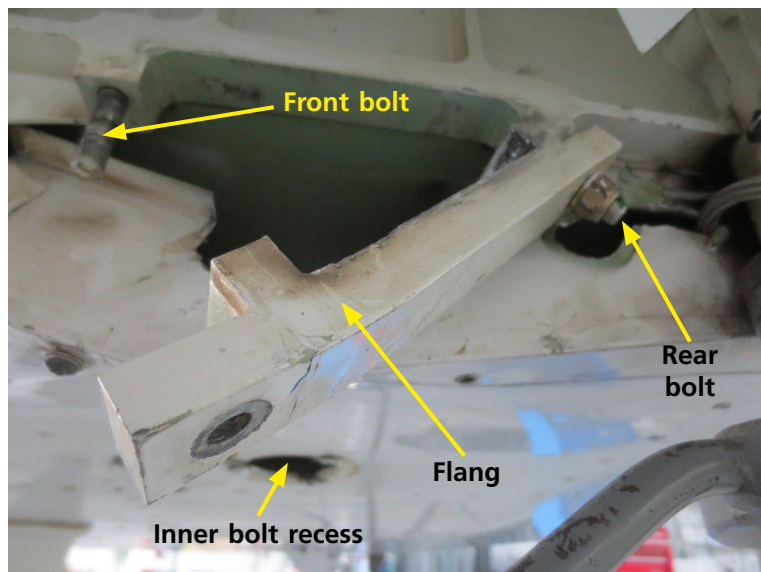

Figure 5. Photograph of the attachment points of the left main landing gear

The right main landing gear was dismantled and its geometry was compared with that of the left gear, noting that the latter was about 15° more open than the right.

The main landing gear mounting assemblies were subjected to further inspections (see 1.18.3).

1.17. Organisational and management information

1.17.1. Information about the training organisation

The operator of the accident aircraft was FLYBAI S.L., an AESA-approved training organisation (E-ATO-166). The operator is based at Burgos Airport (Burgos).

It is authorised to perform:

- CR (A) MEP renewals (ground).
- CR (A) SEP renewals (ground).
- CRI (A) MEP renewals (ground).
- FI (A) renewals.
- IR (A) MEP renewals (ground).
- IRI (A) renewals.
- Integrated ATPL (A).
- Modular ATPL (A).

- Modular CPL (A).
- CR (A) MEP (ground).
- CR (A) SEP (ground).
- CRI (A) MEP (ground).
- FI (A).
- IR (A) MEP (ground).
- IR (A) SEP (ground).
- IRI (A).
- PPL (A) SEP (ground).
- Night flight (A).

1.17.2. Before landing checklist

Electric fuel pump On.

Fuel selector Select fullest.

Landing light On.

Downwind leg:

- Flaps to 15° (T/O).
- Approach speed 65 KIAS.

Final leg:

- Flaps to 40° (FULL).
- Approach speed 55 KIAS.

Carburettor heater: switch off.

Optimal contact speed 55 KIAS.

1.17.3. Operator's standard operating procedure (SOP)

According to the school's procedures, when the aircraft reaches one of the notification points to enter the traffic circuit, it must turn on its landing lights.

The approach procedure must be carried out in the downwind leg (approach and before-landing lists).

On the last third of the downwind leg, when the tip of the wing is level with the runway threshold, adjust the flaps to the first point and switch on the fuel pump.

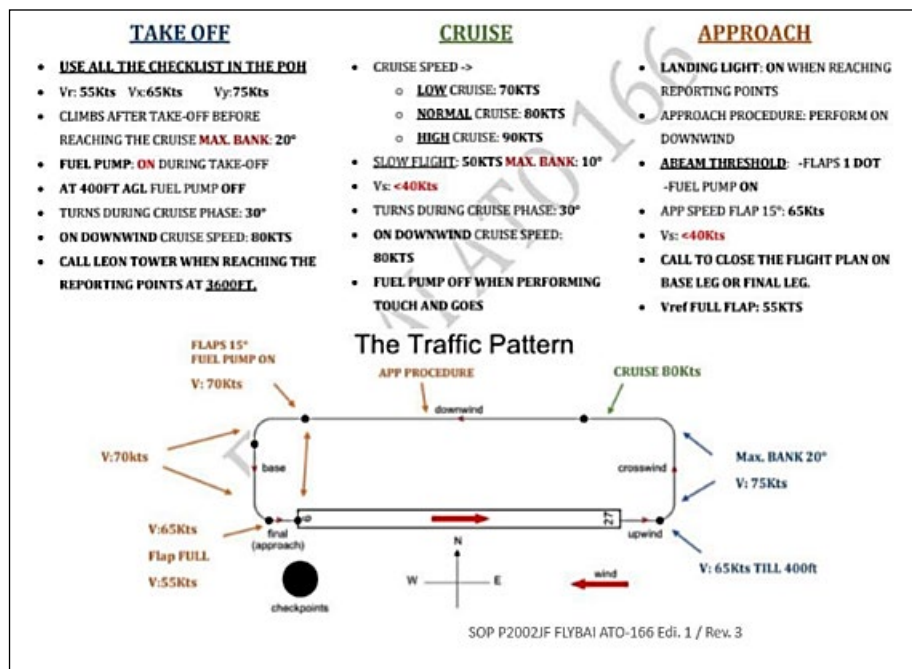

Figure 6. Traffic circuit procedure of the ATO

Adjust the approach speed to 65 kt with flaps at 15°.

Stall speed is less than 40 kt.

Call the Air Traffic control unit on base or final to close the flight plan.

With full flaps, the approach speed is 55 kt.

Figure 6 contains a diagram illustrating the operator's procedures.

1.18. Additional information

1.18.1. Instructor's statement.

The instructor stated that he took off from Burgos airport (LEBG) with a student to carry out a local training flight that lasted 1:30 h.

After performing basic manoeuvres, they proceeded to return to Burgos. Before reaching point W, they heard that the AFIS service had ended. When they reached W, they reported their position to coordinate with other traffic (air-to-air). They joined the right downwind leg for runway 22. There were two other aircraft in the circuit before them, which both landed without incident. In the downwind leg, he took control of the aircraft to land because the student did not yet have enough experience to do so himself.

While in the downwind leg, he configured the aircraft to flaps TO and 65 kt. The approach was stable and within the specified criteria at all times. He did not make any major power changes and maintained speed at +5/-0 kt, with an approach angle of 3° in line with the runway's centre line at all times.

He touched down normally, first with the main gear and afterwards with the nose gear, and then let the aircraft decelerate without applying brakes.

He began to brake when the speed was around 30 kt, noting that the aircraft began to vibrate intensely. He immediately released the brakes, confirmed that the student was not putting pressure on them either and pulled the stick control to relieve the weight on the nose wheel. Given that it doesn't have a shimmy damper, he thought it was the front wheel vibrating. After several seconds of continuous vibrations, the left landing gear began to give way, lowering the wing until it touched the runway. He immediately switched the magnetos, fuel selector, electric fuel pump, and aircraft master switch to OFF, as per the manufacturer's emergency engine-securing procedure in the AFM. The aircraft began to slide at about 25 kt until it came to a stop on the left side of the runway.

After verifying that the student was okay, they proceeded to evacuate the aircraft.

1.18.2. Background information relevant to the failure of the landing gear mounting bolts

Prior to 2012, there were several incidents involving the detachment of at least one side of the main landing gear due to a failure of the threaded main landing gear mounting bolts.

To address the problem, Tecnam adopted the following improvements:

In July 2012, it issued the second edition, revision 1, of mandatory service bulletin SB 066-CS, which affected certain P-92J and P2002-JF models and specified that the nuts on the main landing gear mounting bolts should be replaced by new, larger ones.

The aircraft involved in the incident left the factory equipped with the new nuts.

In 2015, Tecnam modified several of its aircraft's maintenance manuals, including the P2002, to reduce the torque check interval for the main landing gear mounting bolts from every 100 h to every 50 h.

On 28/09/2015, it issued service bulletin SB 214-CS to inform users of the AMM modification concerning the torque check interval for the main landing gear mounting bolts.

According to the aircraft manufacturer, since the replacement of the nuts and the reduction of the torque check interval, they have only been made aware of three landing-gear mounting bolt failures. In all the cases, the cause of the failure was the accidental application of incorrect torque (by default).

1.18.3. Inspection of the threaded elements of the main landing gear mounting system

As described in point 1.6.2, each of the main landing gear legs is attached to the aircraft structure by three nut and through-bolt assemblies; two outer bolts and one inner bolt. The part numbers are as follows:

Mounting point	Bolt	Nut
Inner	MS20006-27	AN365-624A
Front outer	MS20005-30	AN365-524A
Rear outer	MS20005-30	AN365-524A

The parts that failed were the inner bolt (MS20006-27), which was found snapped, and its nut (AN365-624A), and the front outer bolt nut (AN365-524A).

1.18.3.1 Inspection of the inner bolt fragment

The bolt had fractured at the first thread, i.e. at the point where the shank ends and the threaded area begins.

The threaded area has 15 threads. Between threads n° 6 and 10 (counting from the shank), the threads were crushed. The deformation did not affect the entire perimeter of the bolt but covered an arc of about 160°. Furthermore, the bottom of these threads was filled with material from the nut threads.

Between threads n° 10 and 12, there was a fragment of nut thread, corresponding to about two screw turns, which was loose.

At the end of the bolt, there were traces of two different types of safety putty (red and blue), which is used to quickly detect if a nut has come loose. The red putty was probably applied by Tecnam when manufacturing the aircraft because that is the only colour they use. The blue putty must have been applied subsequently, possibly on various occasions after the nut was re-tightened.



Figure 7. Photograph of the sheared fragment of the inner bolt (MS20006-27)

1.18.3.2 Inspection of the inner bolt nut (AN365-624A)

This nut is the self-locking type, with 7 full threads.

A simple inspection with the naked eye revealed that all the threads of the nut had been sheared.

The nut was cut longitudinally, obtaining two halves, "A" and "B" (see figure 8), to be able to inspect the threads from the front.

An inspection of the inner surface of half "A" with a binocular magnifier revealed that the four threads closest to the supporting face of the nut had been wholly sheared, while the three furthest from the seating face retained a little of their height. There were multiple longitudinal marks parallel to the axis of the bolt. There were no anomalies at the bottom of the threads.

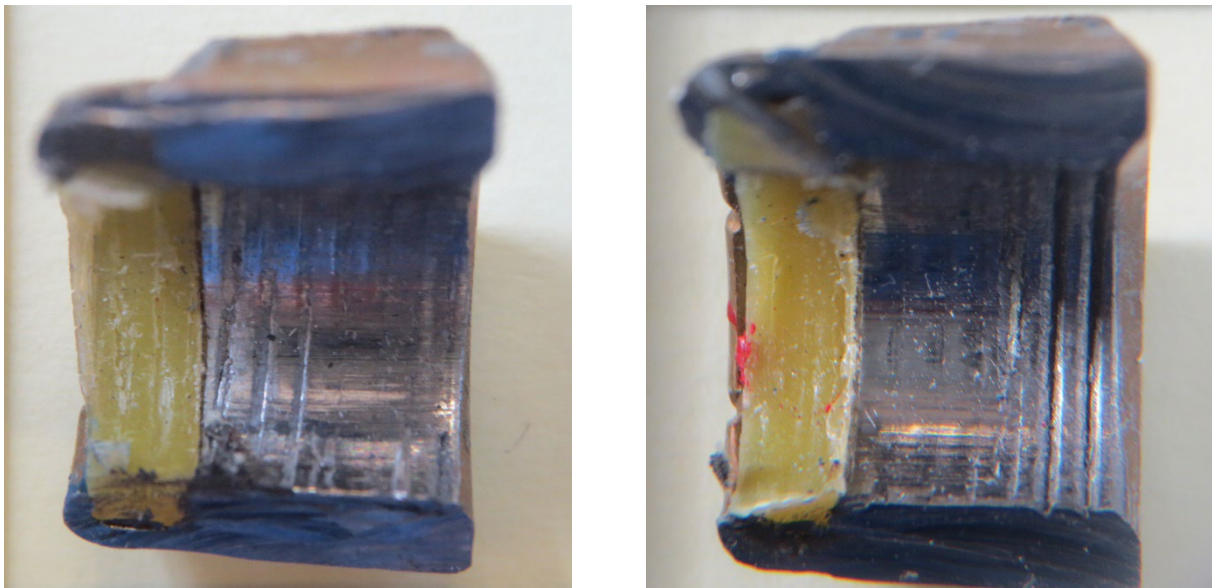

Figure 8. Photographs of the inner bolt nut AN-365-624A, half "A" (left) and half "B" (right)

The four threads closest to the nut's outer face in half "B" were also sheared. However, the three remaining threads, which are the closest to the seating face, retained approximately half their height. There were multiple longitudinal marks parallel to the axis of the bolt.

1.18.3.3 Inspection of the front outer bolt nut (AN365-524A)

A simple visual inspection revealed that all the threads of the nut had been sheared. The nut's inner surface appeared relatively uniform, with alternating bands perpendicular to the axis of the screw, one corresponding to the sheared threads and the other to the bottom of the thread. The entire surface displayed an abundance of marks in an axial direction (parallel to the axis of the screw).

An inspection with the binocular magnifier revealed circumferential scratch marks (marked with a red dashed line in Figure 9) in various places around the sheared threads.

These marks are characteristic of the shear processes that occur when excessive torque is applied due to the relative rotation between the nut and the bolt, which generates the circumferential marks. Had shear only occurred from axial overload, there would only be marks in the axial direction.

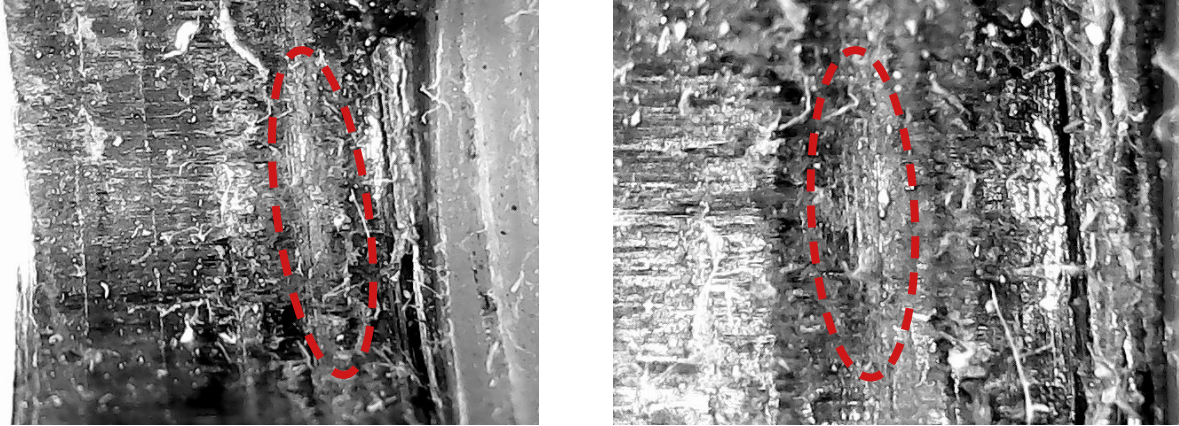

Figure 9. Detail photographs of the sheared threads on the nut (AN365-524A) of the front outer mounting bolt of the left main landing gear

1.18.3.4 Inspection of the rear outer bolt nut (AN365-524A)

The rear outer mounting bolt was deformed by the failure of the other two mountings but did not break, allowing the nut to be removed normally.

This nut was also cut into two halves to compare it with the other two.

A visual inspection did not reveal any apparent abnormalities. The nut retained all its threads with no apparent damage.

An inspection with the binocular magnifier revealed circumferential scratch marks (marked by a red dashed line in Figure 10).

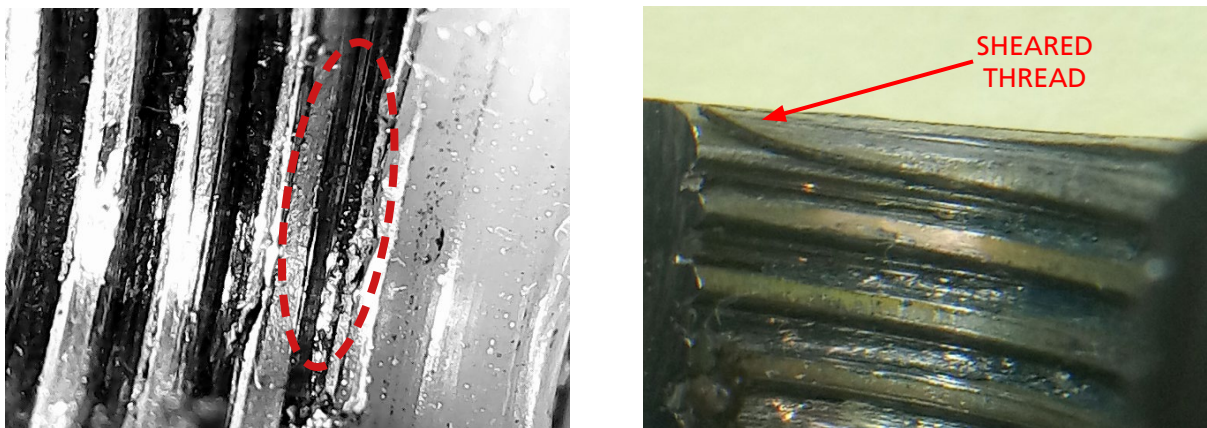

Figure 10. Detail photograph of the circumferential marks on the threads (left) and the sheared section of the first thread

It also revealed that the first thread (the one closest to the nut's seating face) already had a sheared section.

1.19. Useful or effective investigation techniques

Not applicable.

2. ANALYSIS

2.1. Analysis of the breakage of the main landing gear mounting elements

Three landing gear elements broke during the landing: the inner bolt, the inner bolt nut, and the front outer bolt nut.

The failures of these components were sequential. The sequence began when one of them ruptured (primary breakage) and subsequently caused the failure of the other two (secondary breakages).

Therefore, clarification around the issue of which element initiated the sequence is required.

The inner mounting suffered the rupture of two of its components; the bolt which was sheared around the area where the thread begins, and the nut, whose threads were also sheared.

If the bolt had ruptured first, there would be no sheared thread on the nut as it would have ceased to receive loads. However, if the nut ruptured first, while it would have caused the mounting to become loose, the leaf spring damper could have remained in position with the bolt still housed inside it. Without a nut, the bolt would be subjected to shear and bending loads, causing it to break. This circumstance is consistent with the condition of the bolt, which was deformed and displayed crushed threads.

Once we had determined that the bolt breakage was secondary, the next issue to be clarified was which of the two nuts initiated the sequence of breakages.

The examination of the front outer bolt nut showed that two different mechanisms contributed to the shearing of its threads. The radial marks it exhibited are indicative of excess torque being applied during the bolt tightening process, which initiated the breakage due to the partial shearing of the threads. In other words, the threads were only sheared in one part of the thread section, not all of it. As a result of this damage, the strength of the nut decreased. Even so, the nut remained threaded to the bolt until it was subjected to an axial load, possibly of less than its nominal strength, which caused the complete shearing of the threads.

The inspection of the rear outer bolt nut, which did not rupture, revealed radial marks indicative of over-tightening and possibly caused the complete shearing of a section of the thread closer to the supporting face.

Conversely, the examination of the inner bolt nut (AN365-624A) revealed that the threads were sheared by an axial load mechanism, and there was no evidence of previous damage due to over-tightening. However, the three threads closest to the supporting face of the nut displayed appreciable differences in each of the nut halves. This may have been due to an uneven distribution of the axial load, favouring the supporting face and causing the nut to wedge.

Given the above, we can conclude that the following sequence of events caused the failure of the aircraft's left main gear mounting assemblies:

The event started with the failure of the front outer mounting bolt nut due to the shearing of its threads.

In the absence of this nut, the outer landing gear mounting lost its rigidity, allowing the leaf spring damper to move and even rotate around the virtual axis that joins the outer and inner fixings. In these conditions, the load on the internal mounting increased significantly, and its distribution on the supporting face of the nut became extremely uneven, causing it to wedge and shear the threads due to axial overload.

Subsequently, the shearing of the inner bolt occurred following the loss of its nut and the one on the outer front bolt.

The fact that the two outer assembly nuts, which are the same, show damage compatible with an excessive tightening torque indicates, without doubt, that they were tightened to above the nominal torque.

In contrast, the inner assembly nut did not exhibit any markings indicative of over-tightening.

The aircraft's inspection showed that the leaf spring damper on the left main landing gear was more open than that of the right main landing gear. This condition could have been caused by a hard landing, a circumstance not uncommon in school aircraft. In addition to deforming the leaf spring damper, a hard landing could potentially also have damaged the mounting bolts of the left main landing gear, which would further compound the damage caused by the excessive tightening torque.

2.2. Maintenance analysis

According to the information provided by the maintenance organisation, the left main landing gear mounting bolts, which failed during landing, were the original factory-fitted parts and had not been replaced.

This circumstance is corroborated by the fact that traces of red putty were found on them, seemingly matching the putty used by the manufacturer.

An analysis of the maintenance documentation revealed that the tightening torque of the bolts was regularly checked, in line with the time intervals specified in the maintenance manual.

The torque verification was carried out using a torque wrench, the calibration certificate of which was valid on the date of the incident.

According to the maintenance organisation, the torque values used were 25 Nm for the inner bolt and 15 Nm for the outer ones, which is within the ranges specified in the maintenance manual.

However, as determined in point 2.1, the nuts of the two outer bolts show damage compatible with the application of excessive torque.

Although we cannot rule out the possibility that this may have occurred during factory assembly, it seems far more likely that it occurred during one of the subsequent periodic torque checks.

Furthermore, given that the tightening torque of the outer mounting nuts is 15 Nm, which is 10 Nm less than that of the inner mounting (25 Nm), it is entirely feasible that the inner mounting's torque level was applied to the outer nuts mistakenly or as a result of some other circumstance.

For this reason, we deem it necessary to issue a safety recommendation to the maintenance organisation, suggesting it reviews and improves its procedures to minimise the risk of errors being made when checking the tightening torque of the main landing gear mounting bolts.

2.3. Operational analysis

The crew took off from Burgos Airport to carry out a training flight.

As the student was in the early stages of pilot training, the manoeuvres practised were very basic; ascents, descents and turns. Given that he had not yet started training for landing manoeuvres, the instructor took the controls to perform the approach and landing when they entered the traffic circuit.

According to the instructor's statement, they landed without incident but as the aircraft decelerated, he noticed it was vibrating abnormally. At first, the instructor thought the abnormal movement was coming from vibrations in the nose leg, so he pulled the controls to take some weight off it. However, the vibrations continued, and in that instant, the left main landing gear leg detached from the fuselage. The detached leg was found very close to the aircraft, which suggests it was taxiing at low-speed when the breakage occurred.

The instructor reacted to the incident by trying to maintain directional control of the aircraft on the runway until it came to a complete stop. He then secured it before evacuating.

In light of the information provided by the crew, we have concluded that operational aspects did not play a role in the incident.

2.4. Analysis of the actions taken by the AFIS unit

Although the Burgos Airport flight information service (AFIS) had ended twenty minutes before the time of the accident, the service operator was still in the unit.

He was still listening to the radio communication frequency and immediately realised that an accident had occurred on the airport's runway.

He decided to intervene, notified the fire department of the incident and radioed an aircraft on final approach to inform its crew that the runway was occupied. Being aware that several aircraft were on course for the airport, the operator decided to remain in post.

Given that the accident aircraft was occupying the runway, he requested the AFIS service be re-opened for 1 hour to manage the aircraft still in the air and help them all land safely.

It is considered that the actions taken by the Burgos Airport AFIS operator were highly responsible and contributed to the situation being managed safely and efficiently.

3. CONCLUSIONS

3.1. Findings

- Both the instructor and the student's documentation was valid and in force.
- The aircraft's documentation was also correct, and it had an airworthiness review certificate valid until 01/02/2021.
- There were no limiting meteorological conditions for the flight.
- The left main landing gear detached from the fuselage during the landing roll.
- The aircraft had been maintained in accordance with the approved maintenance programme.
- The records confirm that the tightening torque of the main landing gear mounting bolts had been checked according to the intervals specified in the maintenance manual.
- The nuts from the left main landing gear's outer mounting bolts displayed characteristic over-tightening marks.
- The nut from the left main landing gear inner mounting bolt did not display any characteristic over-tightening marks.

3.2. Causes/contributing factors

The investigation has determined the accident was caused by the detachment of the aircraft's left main landing gear due to the failure of its mounting assemblies.

The application of excessive tightening torque on the left main landing gear's outer mounting nuts is thought to be a contributing factor.

4. OPERATIONAL SAFETY RECOMMENDATIONS

The investigation into the incident has found that the failure of the threaded elements used to attach the main landing gear was probably caused by the application of excessive tightening torque during one of the torque checks, which, according to the aircraft maintenance programme, must be carried out every fifty hours. For this reason, a safety recommendation is issued to the aircraft maintenance organisation, Fly Bai Mantenimiento, S.L., to review and improve its procedures.

REC 22/21: It is recommended that the aircraft maintenance organisation, Fly Bai Mantenimiento, S.L., should review and improve its procedures to minimise the risk of incorrect tightening torques being applied when checking the tightening torque of the main landing gear mounting bolts.